

# LIGHT SKY<sup>®</sup>

FLY DRAGON LIGHTING EQUIPMENT CO.,LTD

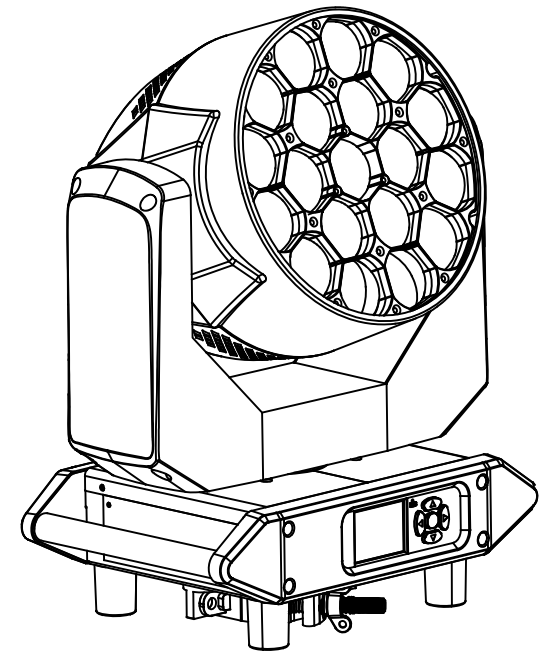

## LIGHT SKY<sup>®</sup>

Tel:0086-20-61828288

Fax:0086-20-61828188 Pc:510800

Web:www.lightsky.com.cn

E-mail: flydragon@lightsky.com.cn

asia@lightsky.com.cn

india@lightsky.com.cn

europa@lightsky.com.cn

latinamerica@lightsky.com.cn

middle-east@lightsky.com.cn

american@lightsky.com.cn

Address: No. 43, Yunfeng Road, Xiuquan Street,  
Huadu District, Guangzhou, China

地址：广州市花都区秀全街云峰路43号



LIGHT SKY<sup>®</sup>



## TX1920-HC

### USER MANUAL

Please read these user manual carefully before use!

## Contents

- 1. Safety information.....2
- 2. Technical information.....4
- 3. Attachment and body size.....6
- 4. Installation and connecting.....7
- 5. Control panel.....10
- 6. Menu setting.....11
- 7. Channel function.....13
- 8. Circuit connecting diagram.....14
- 9. Cleaning and maintenances.....15
- 10.Troubeshooting.....16
- 11.Duty exonerative and copyright protection.....17

Congratulations on choosing our company product! We thank you for your custom.

- ◆Please note that this product, as all the others in the rich my company range, has been designed and made with total quality to ensure excellent performance and best meet your expectations and requirements.
- ◆Carefully read this user manual in its entirety and keep it safe for future reference. It is essential to know the information and comply with the instructions given in this manual to ensure the fitting is installed, used and serviced correctly and safely.
- ◆My company disclaims all liability for damage to the fitting or to other property or persons deriving from installation, use and maintenance that have not been carried out in conformity with this user manual, which must always accompany the fitting.
- ◆My company reserves the right to modify the characteristics stated in this user manual at any time and without prior notice.

## SAFETY INFORMATION



■ This lighting fixture is for professional use only - it is not for household use.

### ■ Installation

Make sure all parts for fixing the projector are in a good state of repair. Make sure the point of anchorage is stable before positioning the projector. The safety chain must be properly hooked onto the fitting and secured to the framework. When suspending the fixture, ensure that the supporting structure and all hardware used can hold at least 10 times the weight of all the devices they support.



### ■ Mounting surface and fire protection

Please do not install the fixture onto combustible surface.

Keep all combustible materials at least 20 cm away from the fixture.

Ensure a minimum clearance of 0.2m around the cooling fans and ventilation.



Do not expose the front glass to sunlight or other strong light source from any angle. Lenses can focus the sun's rays inside the fixture, creating a potential fire hazard.

ta40°C



### ■ Maximum ambient temperature

The fixture is intended for indoor application. Do not operate the fixture if the ambient temperature (Ta) exceeds 40°C.



### ■ Protection against electrical shock

Connection must be made to a power supply system fitted with efficient earthing (Class I appliance according to standard EN 60598-1). It is, moreover, recommended to protect the supply lines of the projectors from indirect contact and/or shorting to earth by using appropriately sized residual current devices.



### ■ Connection to mains supply

The double insulation between the LV power supply and the control conductor on the fixture. Connection to the electricity mains must be carried out by a qualified electrical installer. Check that the mains frequency and voltage correspond to those for which the projector is designed as given on the electrical data label.

This label also gives the input power to which you need to refer to evaluate the maximum number of fittings to connect to the electricity line, in order to avoid overloading.

Don't use the power cable when the insulation is damaged.

It must be the manufacturer or distributor or the professional person to change the damaged power cable in order to avoid any dangerous.



tc 60 °C



■ **Temperature of the external surface**

The maximum temperature that can be reached on the external surface of the fitting, in a thermally steady state, is 60°C. Avoid contact by persons and materials. Allow the fixture to cool for at least 5 minutes before handling.



■ **Maintenance**

Before starting any maintenance work or cleaning the projector, cut off power from the mains supply. After switching off, do not remove any p



■ **The light source**

The light source in this fixture shall be replaced by the manufacturer or its service agent or similar qualification. Always disconnect from mains before replacing the light.



■ **Protection against explosion**

The protection screen, lens or ultraviolet screen on the lamp can be damaged to the degree of failure if visible damage, such as a crack or deep mark, should be replaced.



■ **Protection optical radiation**

Never look directly into the light source. You risk injury to your retina, which may induce blindness.



Do not look at LEDs with magnifiers, telescopes, binoculars or similar optical instruments that may concentrate the light output.



The products referred to in this manual conform to the European Community Directives to which they are subject:

Low Voltage 2014/35/EU

Electromagnetic Compatibility 2014/30/EU

## TECHNICAL INFORMATION

- **Power supplies available:** 100V~240V~ 50/60Hz
- **Power:** 410W
- **LED chip:** TYANSHINE 20W, White 3000K~6000K LED.
- **LED QTY:** 19PCS/ (W1、W2) .
- **Average life:** 30000h
- **Beam angle:** Zoom function min.7°,max.55°.
- **CCT:** 3000K~6000K
- **CRI:** Ra≥90
- **Optical system :** High precision combination structure, high permeable glasslight rod +PMMA lens.
- **Zoom system:** Linear electric zoom.
- **Strobe:** 1-30 times/ second electronic strobe and random strobe.
- **Dimmer:** Electronic dimmer, provides four dimming options.
- **Pan、Tilt:**
  - X/Y Travel: 540°/210°
  - X/Y Resolution: 2.11°/0.82°
  - X/Y Speed: 2.5S/1.0S
- **Control Mode:** DMX512, RDM.
- **Channel:** Standard (13CH)
- **Display Menu:**
  - The display panel adopts a 2.4-inch LCD12864 LCD screen, which is used in both Chinese and English languages to facilitate quick operation and browse menus.
  - Display board can record device's using time, show device's temperature, channel data and software version.
  - Customizable Settings display menu Settings, through the menu can be edited or called built-in The program.
- **Software upgrade :** Upload the upgrade file through the DMX interface.
- **IP20 protection:**
  - Protected against the entry of solid bodies larger than 12mm.
  - No protection against the entry of liquids.
- **Safety Devices:**
  - BIPOlar circuit breaker with thermal protection.
  - Automatic break in power supply in case of overheating or failed operation of cooling system.
- **Cooling:** Forced ventilation with axial fans.
- **Working mode:** Silent mode;Standard mode; High Brightness mode.
- **Outlooking:** Metal base and anti-fire plastic.
- **Light size:** 338X216X422
- **Box Size:** 400X270X495MM  
N.W.: 10.6kg, G.W.: 12.6kg
- **Flycase Size(4sets):**  
920X580X615MM  
N.W.: 42.4kg, G.W.: 78.8kg

### Distance, spot diameter and illumination diagram

55° Lux(fc)	W1	1070(99)	394(37)	217(20)	13(1)
	W2	1000(93)	350(33)	187(17)	96(9)
	W1+W2	1900(177)	670(62)	346(32)	200(19)
7° Lux(fc)	W1	16700(1552)	6100(567)	3230(300)	1600(149)
	W2	14600(1357)	5400(501)	3715(345)	1420(132)
	W1+W2	28700(2667)	9900(920)	5443(506)	2750(256)

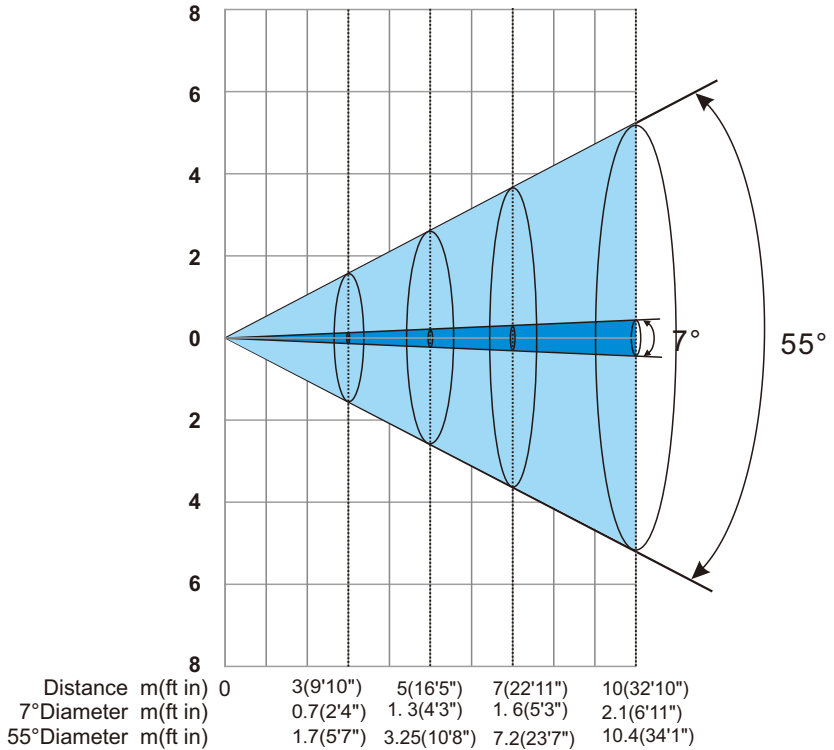

## ATTACHMENT AND BODY SIZE

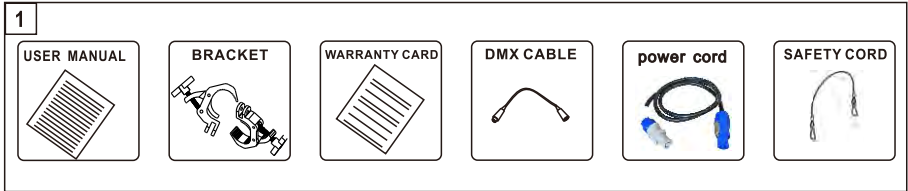

Attachment contents- Fig. 1

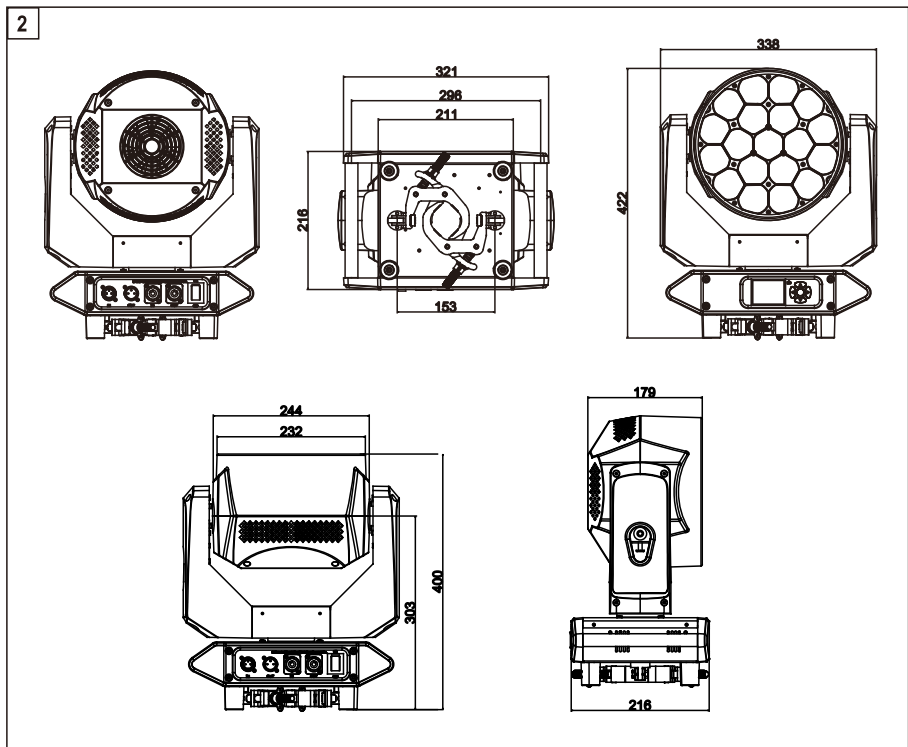

Body Size---Fig 2

## INSTALLATION AND CONNECTING

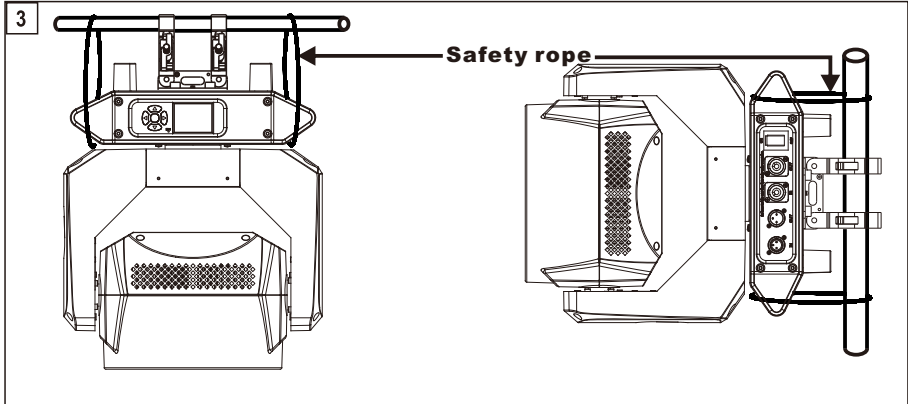

Installing the projector- Fig. 3

Compact, standard clamp system equipped & easy installation

The projector can be installed on the floor resting on special rubber feet, on a truss or on the ceiling or wall.  
**WARNING:** with the exception of when the projector is positioned on the floor, the safety rope must be fitted. This must be securely fixed to the support structure of the projector and then connected to the fixing point at the centre of the base.

Make sure all parts for fixing the projector are in a good state of repair.

Make sure the point of anchorage is stable before positioning the projector.

When suspending the fixture, ensure that the supporting structure and all hardware used can hold at least 10 times the weight of all the devices they support.



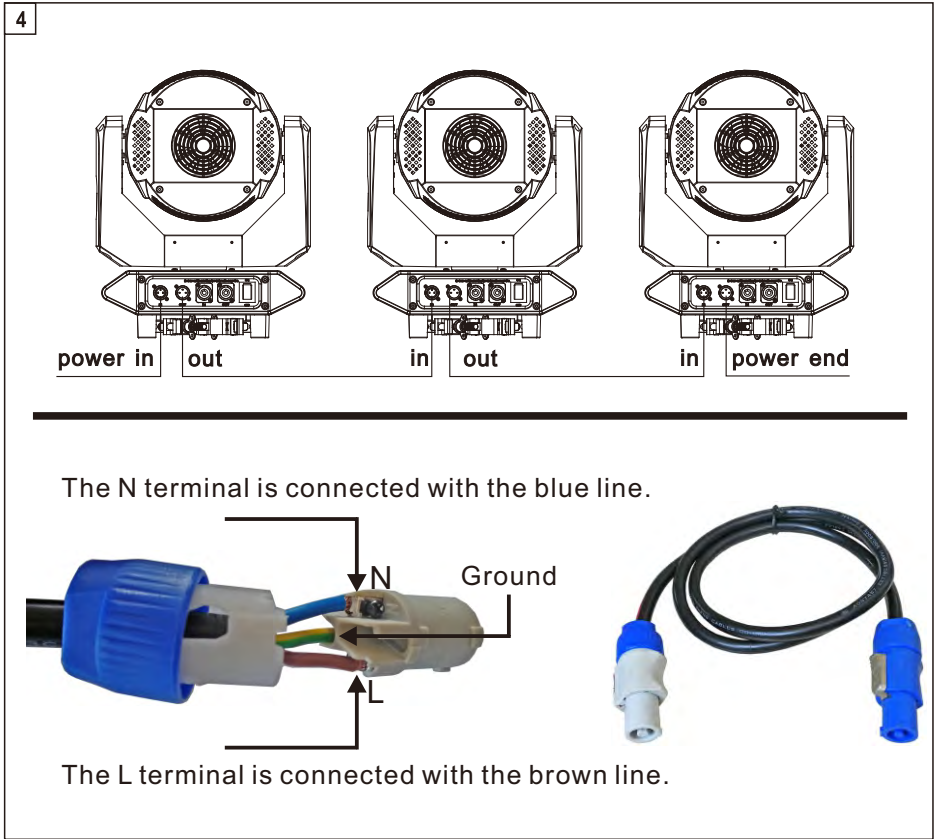

Connecting to the mains supply ---Fig 4

- The stage lighting power supply can not be more than 2pcs pre line
- connection to the electricity mains must be carried out by a qualified electrical installer.
- After doing the above operation and making sure all the devices had been installed with natural operate, press the power switch to check whether every -thing is working normally.

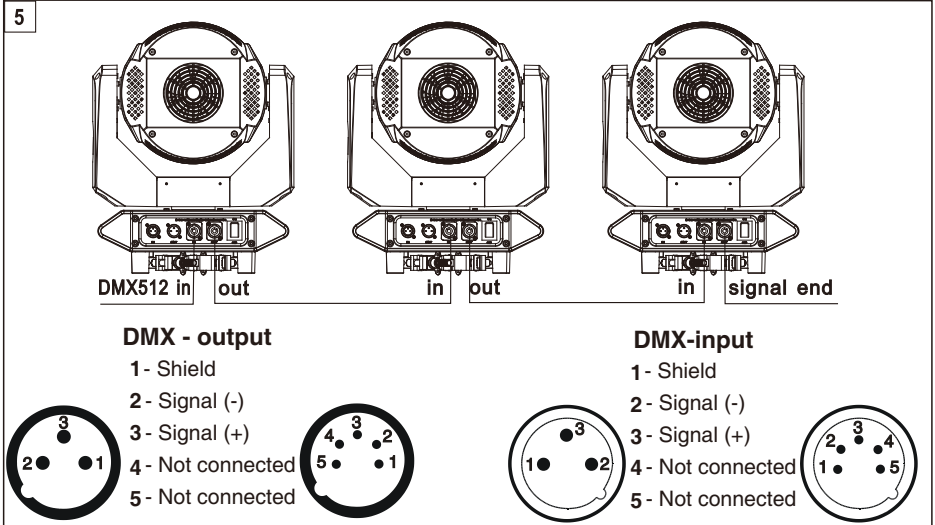

**Connecting to the control signal line (DMX) - Fig. 5**

© Please use the round 3 or 5-pin XLR plugs & sockets offered by menu facture to connect the first projector's output to the second projector' input and connect the second projector's output to the third projector's input. And in the same way for the rest, eventually connect the last projector's output, all the projectors are together.

© The projectors's control signal output or input by using the 3 or 5-pin XLR pug and socket. If need to lengthen the communication cable, please make sure the both side of 3 or 5-pin plug is one to one . (one to one, two to two, three to three). Otherwise, the communication cable will be interrupted. The communicate cable is 2-cord screened cable 75Ω resistance with each core is at least a 0.5mm diameter. **(Caution:** All the inside leading wire of 3 or 5-pin XLR plug couldn't touch each other or plinth).

© Recommend to use the DMX signal terminator for the installation to avoid the electronic noise dama -ge the digital control signal. Simply speaking, DMX terminator is an XLR connector with a 120Ω 1/2W resistor connected across pin 2 and 3. Which is then plugged into the output socket on the last projec -tor in the chain. Refer to the connection.

## CONTROL PANEL

6

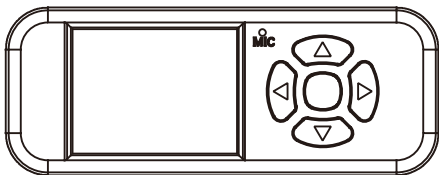

- Up arrowhead : page up
- Down arrowhead : page down
- Left arrowhead : reduce
- Right arrowhead : increase
- Enter : OK function
- Exit : in the choice screen

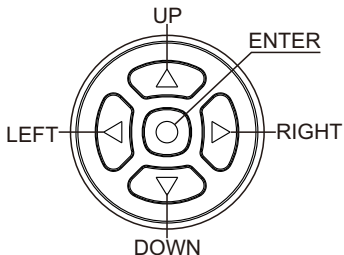

● Press the switch. The projector starts resetting the effects. At the same time, the following information scrolls on the display (please refer to the actual material):

# LIGHT SKY®

DMX:  
001 DMX Address

Service

Information

Lamp

Personal

Language EN Language

Manual control

Reversal

### ● Color Calibration System

Because LED chip's brightness and wave length can not be produced exactly same by LED factory, which would cause the color difference in the LED color fixture. To solve the issue, LIGHT SKY adopts a calibration system by calibrating each color's brightness curve and defining a standard color area. then apply this standard into all the LED fixture to lower the color difference.

So, in MENU Optional of Open Calibration OFF/ON in PERSONAL is available. Standard production, the Calibration system in ON. But user can choose OFF as well

**MENU SETTING**

Mairmenu		I menu	II menu	III menu	IV menu	
DMX setting	>	Address	> 001 - 512			
		Channel mode	Standard (13)			
		State	> Blackout > Hold > Auto			
Info	>	Fixture times	Power on time	> 0 - 99999H		
			LED on time	> 0 - 99999H		
			All time	> 0 - 99999H		
		Fan speed	LED fan	> 0 - XXXXX		
			Power fan	> 0 - XXXXX		
		Fan voltage	LED fan	> 0 - XX. XV		
			Power fan	> 0 - XX. XV		
		Temperatures	> LED TEMP	> (-40℃ - 125℃)		
		RDM info	> 0x3888XXXXXX			
		DMX live	>	1. Pan	> 0 - 255	
				2. Pan fine	> 0 - 255	
				3. Tilt	> 0 - 255	
				4. Tilt fine	> 0 - 255	
5. P/T Speed	> 0 - 255					
6. Function	> 0 - 255					
7. Dimmer	> 0 - 255					
8. Dimmer fine	> 0 - 255					
9. Strobe	> 0 - 255					
10. Cold white	> 0 - 255					
11. Warm white	> 0 - 255					
Version	>	12. CCT	> 0 - 255			
		13. Zoom	> 0 - 255			
Person	>	Pan/Tilt	Display	> VX. XXX		
			Pan/Tilt	> VX. XXX		
			LEDDRV	> VX. XXX		
			PT swap	> OFF > ON		
			Pan invert	> OFF > ON		
			Tilt invert	> OFF > ON		
	Led Hz	>	3000Hz			
			6000Hz			
			12000Hz			
			24000Hz			
	Dimmer Curve	>	Linear			
			Square			
			I-Square			
SCurve						
Dimmer Speed	>	Fade				
		Snap				
Fan mode	>	Silent mode				
		Standard mode				
		Hot mode				
Display	>	Language	> English > Chinese			
		Backlight time	> Always > Auto (30S)			

Main menu		I menu		II menu		III menu		IV menu	
Person	>	Display	>	Intensity	>	0 - 100			
				Rotation	>	Normal Rotate			
		Master/Slave	>	Master Slave					
Manual	>	Manual Control	>	1. Pan	>	0 - 255			
				2. Pan fine	>	0 - 255			
				3. Tilt	>	0 - 255			
				4. Tilt fine	>	0 - 255			
				5. P/T Speed	>	0 - 255			
				6. Function	>	0 - 255			
				7. Dimmer	>	0 - 255			
				8. Dimmer fine	>	0 - 255			
				9. Strobe	>	0 - 255			
				10. Cold white	>	0 - 255			
				11. Warm white	>	0 - 255			
				12. CCT	>	0 - 255			
				13. Zoom	>	0 - 255			
		Reset	>	Pan/Tilt reset Zoom reset Total reset					
		Test	→	Test all	>	test in process			
Test pan/tilt	>			test in process					
Test effects	>			test in process					
Service	→	Fixture state	>	Memory IC		OK/ Reset/ Error			
				Pan Encodeer		OK/ Reset/ Error			
				Pan Drive IC		OK/ Reset/ Error			
				Tilt Encoder		OK/ Reset/ Error			
				Tilt Drive IC		OK/ Reset/ Error			
				Pan		OK/ Reset/ Error			
				Tilt		OK/ Reset/ Error			
				Zoom		OK/ Reset/ Error			
				Pan	>	0 - 255			
				Tilt	>	0 - 255			
	Zoom	>	0 - 255						
	>	Adjust	>	Tilt	>	0 - 255			
				Zoom	>	0 - 255			
				Cold white	>	125 - 255			
		White Balance	>	Warm white	>	125 - 255			
				Factory Reset	Passwo rd	YES NO			
		Factory	>	Reset timers	>	Reset power on timers	Passwo rd	YES NO	
						Reset led timers	Passwo rd	YES NO	
						Reset all timers	Passwo rd	YES NO	
						LOGO	>	LIGHT SKY No LOGO	
		Developer	>	Manual OR DMX	>	Manual Fan Vol	>	DMX Manual	
Manual Fan Vol						>	OFF ON		
Power correlation	>					OFF ON			
LED output power	Passwo rd	50 - 100							

**CHANNEL FUNCTION**

**Standard (13CH)**

Channel	DMX	Percentage	Function	Note
1	0 - 255	0 - 100	Pan	
2	0 - 255	0 - 100	Pan fine	
3	0 - 255		Tilt	
4	0 - 255	0 - 100	Tilt fine	
5	0 - 255	0 - 100	P/T Speed	
6			Function	
	0 - 10		Reserved	
	11 -- 20		Total reset	
	21 -- 30		Pan/Tilt reset	
	31 -- 40		Zoom reset	
	41 -- 50		Silent mode	
	51 -- 60		Standard mode	
	61 -- 70		Hot mode	
	71 -- 80		Pan invert on	
	81 -- 90		Tilt invert on	
	91 -- 100		P/T invert off	
	101 -- 110		PT swap on	
	111 -- 120		PT swap off	
	121 -- 130		Backlight time Always	
	131 -- 140		Backlight time Auto	
	141 -- 150		Linear	
	151 -- 160		Square	
	161 -- 170		I-Square	
	171 -- 180		Scurve	
	181 -- 190		Led Hz 3000HZ	
	191 -- 200		Led Hz 6000HZ	
201 -- 210		Led Hz 12000HZ		
211 -- 220		Led Hz 24000HZ		
221 -- 230		Dimmer Speed Fade		
231 -- 240		Dimmer Speed Snap		
241 -- 255		Reserved		
7	0 - 255	0 - 100	Dimmer	
8	0 - 255	0 - 100	Dimmer fine	
9			Strobe	
	0 - 9		Reserved	
	10 - 199		Strobe-effect from slow to fast	
	200 - 249		Random strobe-effect from slow to fast	
250 - 255		Reserved		
10	0 - 255	0 - 100	Cold white	
11	0 - 255	0 - 100	Warm white	
12	0 - 255	0 - 100	CCT	
13	0 - 255	0 - 100	Zoom	

# CIRCUIT CONNECTING DIAGRAM

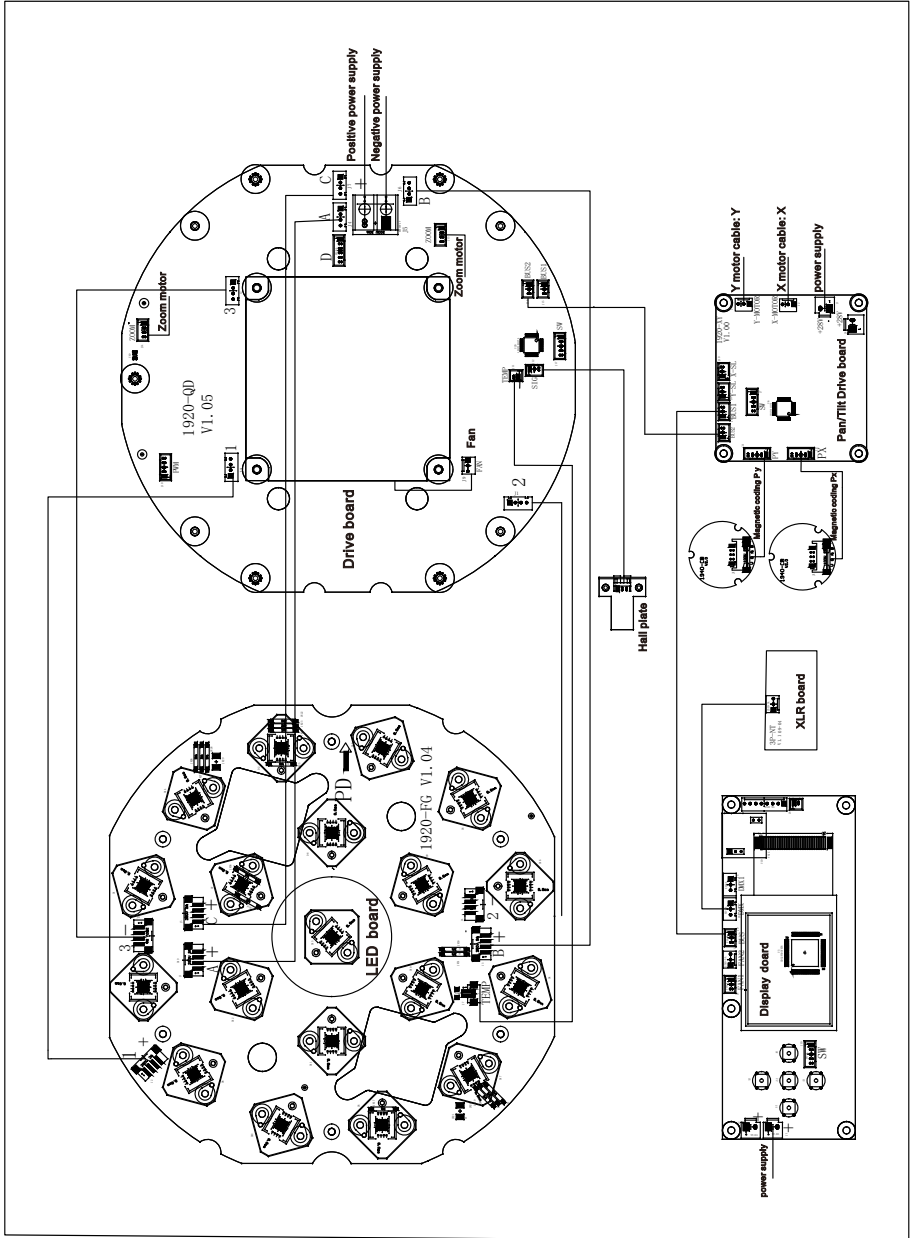

## CLEANING AND MAINTENANCES

- 1. In order to ensure the projector could work normally. It should be kept clean always .  
The lens should also be regularly cleaned to maintain an optimum light output.  
Do not use any type of solvent on lens. It will damage the projector.
- 2. Suggestion: The continue usage of the light don't exceed 4 hours. Or it will shorter the usage of the lamp. Please use the alternative operation to solve this problem.  
The fixture power ON time is best not over 48 hours, or it would generate lamp protection procedure.
- 3. Please disconnect the power supply when begin to maintenance take down the light.  
Please let the parts cool down 10 minute at least then begin to install.
- 4. Please inspect the lens or other moving parts timing and keep them clear and static.  
If find anything damaged or looseness must change a lamp or fix the lamp in order to avoid the accident.  
Please check the machanical parts is jamging. After cleaning, please add some temperature -durable juice.
- 5. The light use the strong cool system. It is easy for the dirty to be colleted. Please do clear the hot-sak one time two week at least.
- 6. After you use the light, please check the intake place whether there are some wastepaper, please clean it up, or the windmill will break down and causing fire.

### CAUTION!

**Disconnect from mains before starting maintenance operation.**



## TROUBESHOOTING

It is recommended some solution for some normal trouble shooting. Any inextricability problems should always be handling by the professional person. Disconnect the power supply before maintenance the light.

### ■ LED off / LED :

- 1.Please check if install the suitable voltage.
- 2.Please check whether the led will reach the end of their life can explode; please replace a same description led.
- 3.Please check if the power supply is enough.
- 4.Please check whether the DMX 512 controller pass the "turn on" order.

### ■The light couldn't accept the control order:

- 1.Please check the start code address and the function option are correct.
- 2.Please check whether the communicate control cable is on good connection or the cable is too long or interrupt.
- 3.Please check the control system is not valid, check the signal amplifier of chain connected is valid.
- 4.Please check whether the communicate cable is too long or the other equipment is mutually conjugate.
- 5.Please arrange the wire well, shorter the signal cable, put the high voltage cable and low voltage cable separately.
- 6.Add the signal amplify isolator.
- 7.Signal cable is used the excellent screening doublet (Resistance 75 OHM ) .
- 8.The end of the light end and the end resistance.

### ■The light can't move:

- 1.Please check if the power supply is suitable for the light voltage data.
- 2.Please check the light if they are deformation, inside parts is broken, become wet etc will lead the loose contact.
- 3.Please check the if the inside lead wire and the connector is loose.
- 4.Please check the electric parts(such as the transformer,PCB board,contrller) is short-circuit or burn down.

■

### On working,the pan &tilt couldn't work normally:

- 1.Please check according to the above step by step.
- 2.Please check the belt of the X.Y is broken.
- 3.Please check the X/Y direction data to the receiver is damage.
- 4.Re-projector reset.

## **DUTY EXONERATIVE AND COPYRIGHT PROTECTION**

- ◇The lamp belongs to consumption products that is not guarantee to keep it in good repair.
- ◇Any products broken that didn't according to the instruction is not guarantee to keep it in good repair.
- ◇The commentary for all the instruction belongs to the supplier in final.
- ◇No authorize can't copy.
- ◇The information in this manual may be changed in the future,the company reserve the right to change the data without any advise.