

# LIGHT SKY

FLY DRAGON LIGHTING EQUIPMENT CO.,LTD

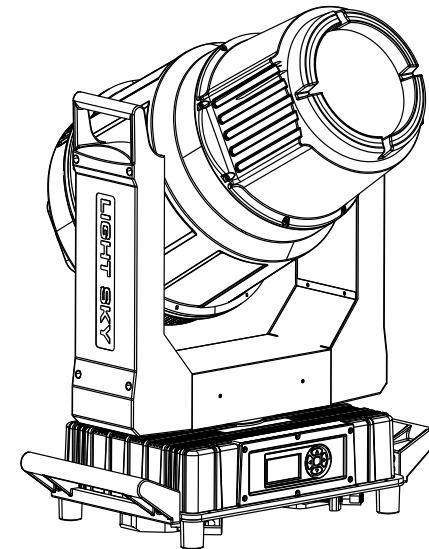

Web: [www.lightsky.com.cn](http://www.lightsky.com.cn)

Tel: 0086-20-61828288

Fax: 0086-20-61828188 Pc: 510820

E-mail: [flydragon@lightsky.com.cn](mailto:flydragon@lightsky.com.cn)

Address: No. 4, Jingneng Road 1,  
Huadu District, Guangzhou, China



**LIGHT SKY**



[WWW.LIGHTSKY.COM.CN](http://WWW.LIGHTSKY.COM.CN)

## SHARK 450BSW

## USER MANUAL

Please read these user manual carefully before use!

# CONTENTS

1. Safety information .....	2
2. Technical information .....	5
3. Attachment and body size .....	9
4. Installation and connecting .....	10
5. Control panel .....	14
6. Menu setting .....	15
7. Channel function.....	18
8. Circuit connecting diagram .....	24
9. Cleaning and maintenances .....	25
10. Troubleshooting.....	25
11. Duty exonerative and copyright protectio.....	27

**Congratulations on choosing our company product! We thank you for your custom.**

- ◆ Please keep in mind that this product, like other products of the company, adheres to the concept of people-oriented design and manufacture, and takes product quality as the foundation.
- ◆ We put the interests of customers first, and do our best to meet customer requirements.
- ◆ Please read this instruction manual carefully and keep it for future reference. In the case of fully understanding the product information, strictly abide by theUse the instruction manual to ensure that the product is installed, used and serviced correctly and safely.
- ◆ Our company is not responsible for any damage to lamps or other performance due to personal failure to follow the instructions during installation, use and maintenance.responsibility.
- ◆ Our company reserves the right to modify the manual at any time and without prior notice.

## SAFETY INFORMATION



Please read the instruction carefully which includes important information about the installation, usage and maintenance.

### WARNING

Please keep this User Manual for future consultation. If you sell the unit to another user, be sure that they also receive this manual.

The following symbols are used to identify important safety information on the product and in this manual:

 <b>DANGER!</b> Safety hazard. Risk of severe injury or death.	 <b>DANGER!</b> Refer to manual before installing, powering or servicing.	 <b>DANGER!</b> Hazardous voltage. Risk of severe or lethal electric shock.	 <b>Warning!</b> Fire hazard.	 <b>Warning!</b> Burn hazard. Hot surface. Not touch. Do not touch.	 <b>Warning!</b> Risk of eye injury. Safety glasses must be worn.	 <b>Warning!</b> Risk of hand injury. Safety gloves must be worn.	 Avoid direct eye contact
 Applies only to luminaires directly mounted on surfaces of non-combustible materials	 Do not discard Trash can	 Mark of ground	 Replace all shatter shields	 Take a short distance from the object to be photographed (meters)	 Rated maximum ambient temperature	 Do not point the lens towards the sun or strong light	 Operation not allowed during runtime

### Important:

**Damages caused by the disregard of this user manual are not subject to warranty.**

**The dealer will not accept liability for any resulting defects or problems.**

- Unpack and check carefully to ensure that there is no transportation damage before using the unit.
- Do install and operate by qualified operator.
- The light source in this luminaire should be replaced by the manufacturer or its service agent or a similarly qualified person, always cut off the power supply before replacing the light source.
- Do not allow children to operate the fixture.
- Use safety chain when fixing the unit. Handle the unit by carrying its base instead of head only.

- The unit must be installed in a location with adequate ventilation, at least 20cm from adjacent surfaces.
- Be sure that no ventilation slots is blocked, otherwise the unit will be overheated.
- Before operation, ensure that you are connecting this product to the proper voltage in accordance with the specifications in this manual or on the product's specification label.
- It's important to ground the yellow/green conductor to earth in order to avoid electric shock.
- Minimum ambient temperature Ta:  $-20^{\circ}\text{C}$ . Maximum ambient temperature Ta:  $40^{\circ}\text{C}$ . Do not operate this product at a lower or higher temperature.
- Do not connect the device to any dimmer pack.
- When the lamp is running, do not place combustible objects next to it. The shortest distance between the device and inflammable and explosive objects or materials is 0.5m.
- Make sure the power cord is not crimped or damaged; replace it immediately if damaged.
- Unit's surface temperature may reach up to  $\leq 80^{\circ}\text{C}$ . do not touch the housing bare-handed during its operation.
- Avoid any flammable liquids, water or metal from entering the unit. once it happens, cut off the mains power immediately.
- Do not operate in a dirty or dusty environment. do clean the fixture regularly.
- Do not touch any wire during operation as there might be a hazard of electric shock.
- Avoid entanglement of the power cord with other wires.
- The minimum distance to objects/surface must be more than 12 meters.
- In the event of serious operating problem, stop using the unit immediately.
- Never turn on and off the unit time after time.
- The housing, the lenses, or the ultraviolet filter must be replaced if they are visibly damaged.
- Do not open the housing as there are no user serviceable parts inside.
- Do not attempt to operate this unit if it becomes damaged. do not attempt any repairs yourself. Repairs carried out by unskilled people can lead to damage or malfunction. Please contact the nearest authorized technical assistance center if needed.

- Disconnect this product from its power source before servicing.
- Do use the original packaging if the device is to be transported.
- Avoid direct eye exposure to the light source while the product is on.
- Do not operate this product if you see damage on the housing, shields, or cables.  
Have the damaged parts replaced by an authorized technician at once.

**Installation:**

The fixture should be fixed on the clamp. Always ensure that the unit is firmly fixed to avoid vibration and slipping off during operation. Ensure that the trussing or area of installation must be able to hold 10 times the weight without any deformation. Always install a safety cable that can hold at least 12 times the weight of the fixture when installing.

Do install and operate by qualified operator. It must be installed in a place where there is out of the reach of people.

## TECHNICAL INFORMATION

### OPTICS

- Light source: NSL- 450 USHIO LIGHT SKY
- Optical angle: Beam mode 2 ° -21 °, Spot mode 3 ° -42 °
- Optical lens: coated with high anti reflective film,  $\phi$ 160mm
- Color temperature: 7000K
- Color rendering index: Ra $\geq$ 74
- Illuminance: 422000 lux@10 rice
- Expected service life of light source: 1500H (data provided by the light source supplier)

### COLOUR

- Color: 14 color chips+white light, capable of achieving bidirectional color rainbow, dual color step gradient (linear movement), bidirectional rotation of color wheel, random color mode
- Color mixing system: independent CMY color mixing system, free color mixing

### PATTERN

- Fixed pattern: 11 patterns+white light+3 types of animations (animation effect patterns) with bi-directional shaking, animation, and flowing effects
- Activity pattern: 8+1 activity pattern disc, pluggable and replaceable, capable of bidirectional shaking and flowing effect, pattern size is  $\phi$  11, outer size is  $\phi$  15.9

### EFFECT

- 4 Prisms: 1 Beam Prism, 3 Pattern Prisms, Bidirectional Rotation, Independent Switching, Stackable
- Soft light effect: adjustable independent soft light effect
- Strobe: 0.5-9 times/second adjustable pulse flicker and random flicker
- Dimming: 0-100% linear adjustment
- Focusing: High precision electric focusing

### CONTROL AND PROGRAMMING

- Control channel: 28CH, please refer to the channel table for details
- Protocol: Standard DMX512 protocol and RDM protocol
- ArtNet protocol (optional)
- Data connection: Three core or five core signal input/output
- RJ45 interface (optional)
- Display: LCD screen
- Upgrade software through DMX signal

## **X/Y AXIS MOTION ANGLE**

- X-axis: 540 ° 8-bit/16bit precision scanning
- Y-axis: 250 ° 8-bit/16 bit precision scanning
- Reset function with automatic error correction
- Fixed lock: Y-axis lock

## **POWER SUPPLY AND POWER**

- Input voltage: AC 100-240V 50/60Hz
- Maximum power: 700W
- Power factor: 0.985
- Maximum current of the lamp: 3.2A/220V, 7A/100V

## **DIMENSION**

- Product size: 509 × 320 × 754mm
- N.W.: 38.5kg
- Carton packaging (default): 810 × 580 × 395mm
- G.W.: 42.5kg
- Flycase Size (1 sets): 620 × 665 × 830 mm
- G.W.: 74.0kg

## **OTHER**

- Protection level: Ip66
- Work environment: - 20 °C ~ 40 °C

(Note: When the lamp is working in an environment below zero degrees Celsius and powered on, the bulb needs to be preheated for 30 minutes before resetting all functions of the lamp before it can be used normally.)

- Maximum surface temperature of lamp body: ≤ 80 °C

## **APPROVALS**

- The product implementation standard: GB/T 7000.1-2023 、 GB/T 7000.217-2023
- Approved certifications: CE、RoHs
- The product complies with the following EU directives:
- Low Voltage Directive 2014/35/EU . EMC Directive 2014/30/EU

distance, spot diameter and illumination diagram (Beam model)

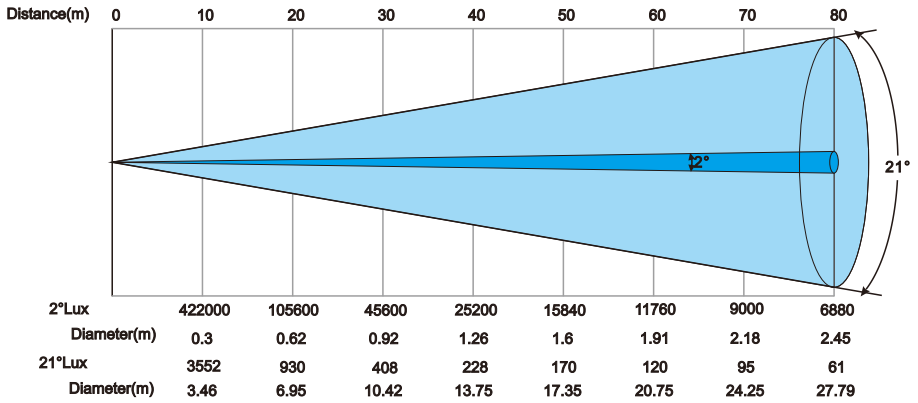

distance, spot diameter and illumination diagram (Spot model)

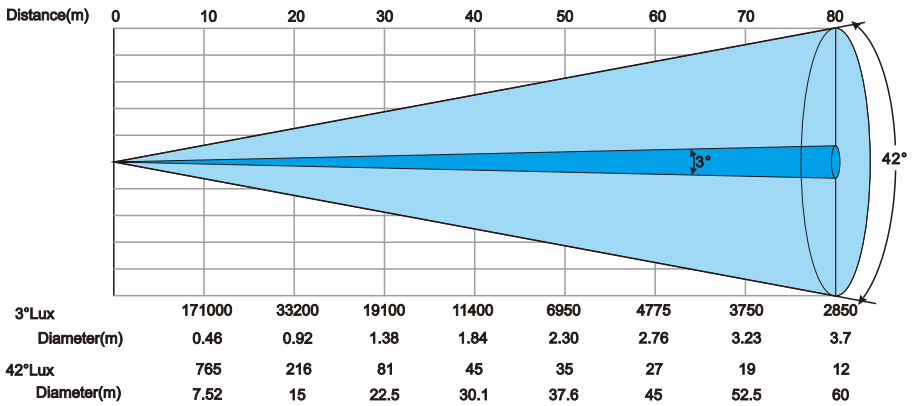



1



Static gobo wheel  
(please refer to the actual material)

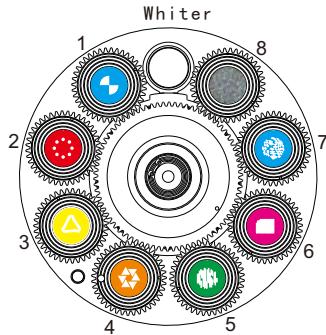

Rotating gobo wheel  
(please refer to the actual material)

2

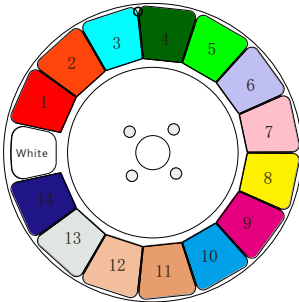

Color wheel  
(please refer to the actual material)

1	Dark red
2	Orange
3	Aquamarine
4	Dark
5	Green
6	Lavender
7	Pink
8	Yellow
9	Magenta
10	Cyan
11	CT02
12	CT01
13	CTB
14	Dark blue

3



**C**

**M**

**Y**

CMY color mixing system

## ATTACHMENT AND BODY SIZE

Attachment contents- Fig. 1

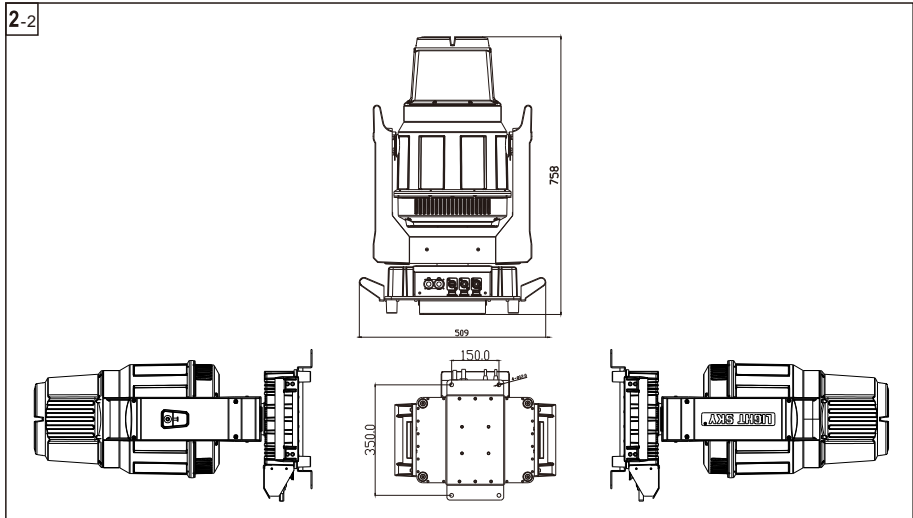
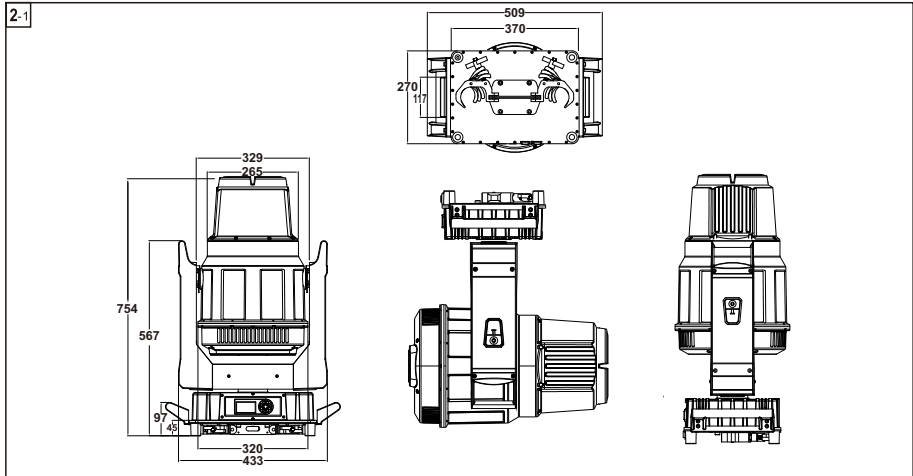
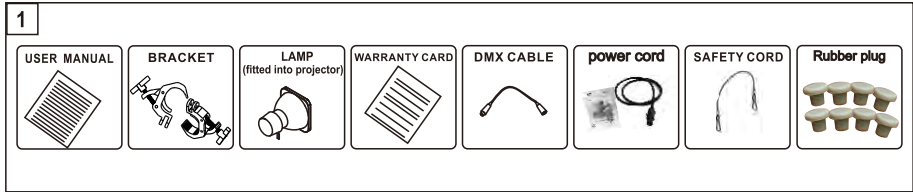

## INSTALLATION AND CONNECTING

3

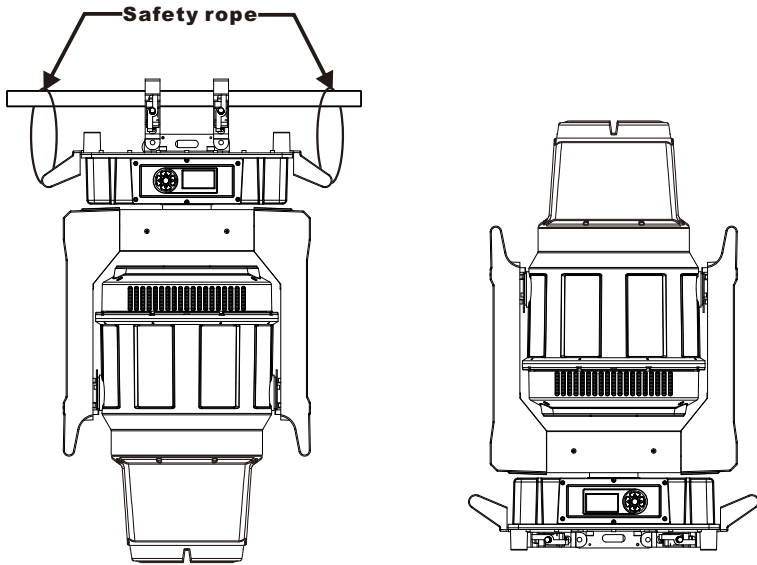

Installing the projector- Fig. 3

The projector can be installed on the floor resting on special rubber feet, on a truss or on the ceiling or wall.  
**WARNING:**with the exception of when the projector is positioned on the floor, the safety rope must be fitted.  
This must be securely fixed to the support structure of the projector and then connected to the base handle.

Make sure all parts for fixing the projector are in a good state of repair.

Make sure the point of anchorage is stable before positioning the projector.

When suspending the fixture, ensure that the supporting structure and all hardware used can hold at least 10 times the weight of all the devices they support.

4

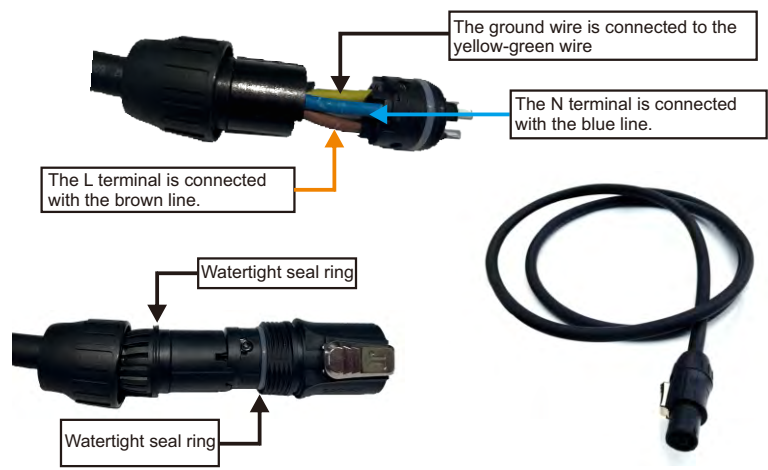
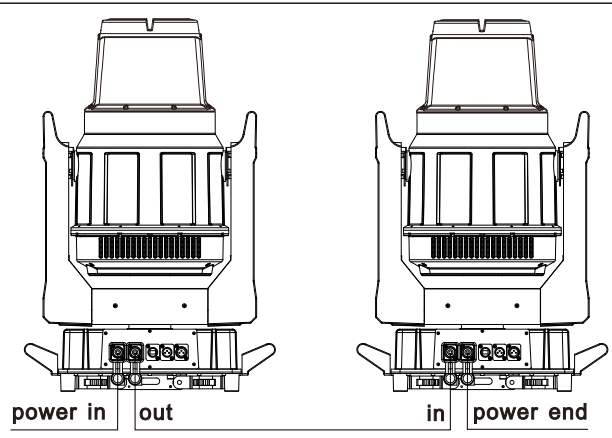

Connecting to the mains supply ---Fig 4

- The stage lighting delivers a three-core waterproof plug.
- The stage lighting power supply can not be more than 2pcs pre line.
- Connection to the electricity mains must be carried out by a qualified electrical installer.
- After doing the above operation and making sure all the devices had been installed with natural operate, press the power switch to check whether everything is working normally.

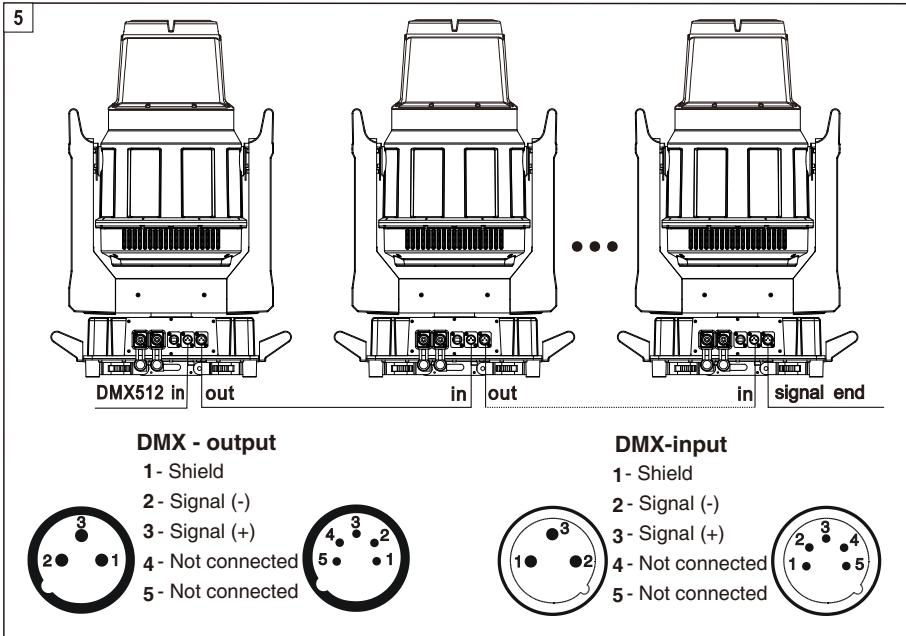

**Connecting to the control signal line (DMX) - Fig. 5**

© Please use the round 3 or 5-pin XLR plugs & sockets offered by menu facture to connect the first projector's output to the second projector' input and connect the second projector's output to the third projector's input. And in the same way for the rest, eventually connect the last projector's output, all the projectors are together.

© The projectors's control signal output or input by using the 3 or 5-pin XLR pug and socket. If need to lengthen the communication cable, please make sure the both side of 3 or 5-pin plug is one to one . (one to one, two to two, three to three). Otherwise, the communication cable will be interrupted. The communicate cable is 2-cord screened cable  $75\ \Omega$  resistance with each core is at least a 0.5mm diameter. (**Caution:** All the inside leading wire of 3 or 5-pin XLR plug couldn't touch each other or plinth).

© Recommend to use the DMX signal terminator for the installation to avoid the electronic noise dama -ge the digital control signal. Simply speaking, DMX terminator is an XLR connector with a  $120\ \Omega$   $1/2W$  resistor connected across pin 2 and 3. Which is then plugged into the output socket on the last projec -tor in the chain. Refer to the connection.

6

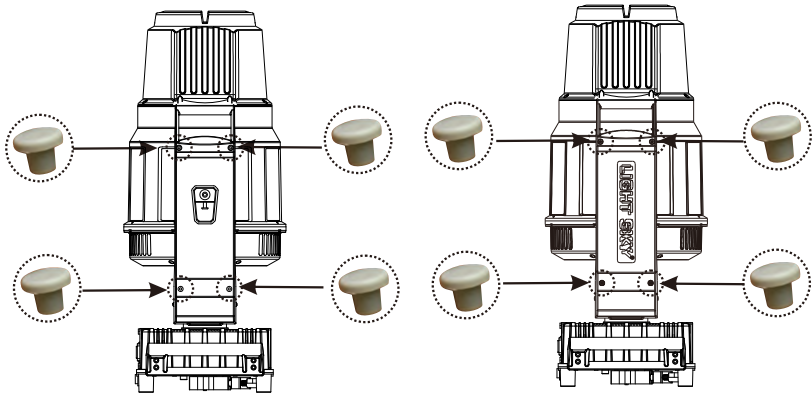

Please install the rubber plug before use.

## CONTROL PANEL

7

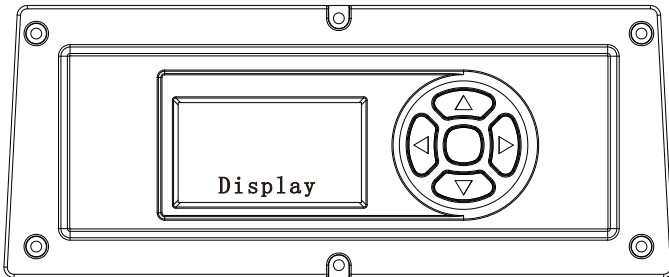

- Up arrowhead : page up
- Down arrowhead : page down
- Left arrowhead : reduce
- Right arrowhead : increase
- Enter : OK function
- Exit : in the choice screen

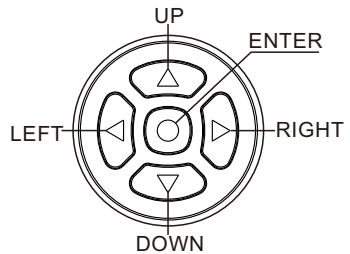

- Press the switch. The projector starts resetting the effects.  
At the same time, the following information scrolls on the display  
(please refer to the actual material)

8



DMX:  
001 DMX Address



Information



Personal



Manual control



Service



Lamp



language  
EN Language



Reversal

## MENU SETTING(V1.0)

Main menu	I menu	II menu	III menu	
DMX Address	→ Address :001-512			
Information	Total Time	→ Power :****(h) Lamp ON :****(h)		
	Lamp Hours	→ Total :****(h) Lamp Open :****(h)		
	Temperature	→ E-ball last:000.0 Out Temp In Temp :000.0		
	RDM UID	→ *****		
	Fan speed/Voltag	→	1. L Fan :*. *V	
			2. Out Fan :*. *V	
			3. In Fan :*. *V	
			4. L Fan :****R	
			5. OutFan1 :****R	
			6. OutFan2 :****R	
			7. OutFan3 :****R	
			8. In Fan1 :****R	
			9. In Fan2 :****R	
	DMX Live	→	1. Pan ***	
			2. Pan Fine ***	
			3. Tilt ***	
			4. Tilt Fine ***	
			5. Functions ***	
			6. Dimmer ***	
			7. Shutter ***	
			8. Cyan ***	
			9. Magenta ***	
			10. Yellow ***	
11. Colour ***				
12. StaticGobo ***				
13. Rot Gobo ***				
14. Gobo Rot ***				
15. Prism 1 ***				
16. Prism1 Rot ***				
17. Prism 2 ***				
18. Prism2 Rot ***				
19. PrismMacro ***				
20. Macro Rot. ***				
System Version	→	21. Frost ***		
		22. Zoom ***		
		23. Zoom Fine ***		
		24. Focus ***		
		25. Focus Fine ***		
		26. Focus 2 ***		
		27. AutoFocus ***		
Return (ESC)	→	28. Effect Mac		
		XY :V*. **		
		Gobo : V*. **		
		CMYCMY : V*. **		
		Fan : V*. **		
Prism : V*. **				
		Display : V*. **		



Main menu	I menu	II menu	III menu	
Personal	Auto lamp on	→ OFF ON		
	P/T invert	Pan invert	→ OFF ON	
		Tilt invert	→ OFF ON	
		Return(ESC)		
	Display	Language	→ English Chinese	
		Back Light	→ Open Auto close(15s)	
		Reversal	→ Normal Rota. 180	
		Backlight blink	→ ON OFF	
		Return(ESC)		
	Return(ESC)			
Manual control	Channel control	→ 1. Pan ***		
		2. Pan Fine ***		
		3. Tilt ***		
		4. Tilt Fine ***		
		5. Functions ***		
		6. Dimmer ***		
		7. Shutter ***		
		8. Cyan ***		
		9. Magenta ***		
		10. Yellow ***		
		11. Colour ***		
		12. StaticGobo ***		
		13. Rot Gobo ***		
		14. Gobo Rot ***		
		15. Prism 1 ***		
		16. Prism1 Rot ***		
		17. Prism 2 ***		
		18. Prism2 Rot ***		
		19. PrismMacro ***		
		20. Macro Rot. ***		
		21. Frost ***		
		22. Zoom ***		
		23. Zoom Fine ***		
		24. Focus ***		
		25. Focus Fine ***		
		26. Focus 2 ***		
		27. AutoFocus ***		
		28. Effect Mac		
	Return(ESC)			
	Reset	→ System reset		
		Pan/Tilt reset		
		Gobo reset		
		Color reset		
Dimmer reset				
Zoom reset				

Main menu	I menu	II menu	III menu	
	Test	Effects reset		
		Return(ESC)		
		Test P/T	→ STEP ***	
		Test effect	→ STEP ***	
		Test all	→ STEP ***	
	Return(ESC)			
Service	Error list	→		
	Clean error	→	Keep List Empty List	
	Calibration	→	Pan 000-255	
			Tilt 000-255	
			Dimmer 000-255	
			NC/NC 000-255	
			Focus 000-255	
			Zoom 000-255	
			Colour 000-255	
			Gobo 000-255	
			Prism 1 000-255	
			Prism 2 000-255	
			NC/NC 000-255	
			Frost 000-255	
			Cyan 000-255	
	Magenta 000-255			
	Yellow 000-255			
	Rota. Gobo 000-255			
		Return(ESC)		
	Factory	→	Load default	
			Reset timers	
Developer				
Firmware update				
Return(ESC)				
	return (ESC)			
Lamp	→	Off On		
Language	→	English Chinese		
Reversal	→	Normal Rota. 180		

## CHANNEL FUNCTION(V1.0)

Channel	DMX	Percentage	Function	
1	0-255	0-100	Pan	
2	0-255	0-100	Pan Fine	
3	0-255	0-100	Tilt	
4	0-255	0-100	Tilt fine	
5			Function	
	0-9		Reserved (0=default)	
	10-14		Reserved	
	15-19		Reserved	
	20-24		Reserved	
	25-29		Reserved	
	30-34		Reserved	
	35-39		Reserved	
	40-44		Reserved	
	45-49		Reserved	
	50-54		Reserved	
	55-59		Reserved	
	60-64		Reserved	
	65-69		Reserved	
	70-74		Reserved	
	75-79		Reserved	
	80-84		Reserved	
	85-89		Reserved	
	90-94		Reserved	
	95-99		Reserved	
	100-101		Reserved	
	102-103		Reserved	
	104-105		Reserved	
	106-107		Reserved	
	108-119		Reserved	
	120-124		Reserved	
125-129		Reserved		
130 - 139		Lamp On		
140 - 149		Pan/Tilt reset		
150 - 159		Colour system reset		
160 - 169		Gobo wheels reset		
170 - 179		Dimmer/Shutter reset		
180 - 189		Zoom/focus/frost/prism wheels reset		
190 - 199		Effect wheel reset		
200 - 209		Total reset		
210 - 229		Reserved		
230 - 239		Lamp Off		
240 - 244		Reserved		
245 - 249		Reserved		
250 - 255		Reserved		
6			Dimmer intensity	
	0 - 255		Dimmer intensity from 0% to 100% (0=default)	
7			Shutter/ strobe	
	0 - 31		Shutter closed	
	32 - 63		Shutter open (32=default)	
	64 - 95		Strobe-effect from slow to fast	
	96 - 127		Shutter open	
	128 - 143		Opening pulse in sequences from slow to fast	

Channel	DMX	Percentage	Function
	144 - 159		Closing pulse in sequences from fast to slow
	160 - 191		Shutter open
	192 - 223		Random strobe-effect from slow to fast
	224 - 255		Shutter open, Full lamp power
8			Cyan
	0 - 255		Cyan from min. saturation --> full cyan (0=default)
9			Magenta
	0 - 255		Magenta from min. saturation --> full magenta (0=default)
10			Yellow
	0 - 255		Yellow from min. saturation --> full yellow (0=default)
11			Colour wheel
			Continual positioning
	0-4		White
	5-8		White+Red
	9-12		Red
	13-16		Red+Orange
	17-20		Orange
	21-24		Orange+Aquamarine
	25-28		Aquamarine
	29-32		Aquamarine+Green
	33-36		Green
	37-40		Green+Light Green
	41-44		Light Green
	45-48		Light Green+Lavender
	49-52		Lavender
	53-56		Lavender+Pink
	57-60		Pink
	61-64		Pink+Yellow
	65-68		Yellow
	69-72		Yellow+Magenta
	73-76		Magenta
	77-80		Magenta+Cyan
	81-84		Cyan
	85-88		Cyan+CT0 260
	89-92		CT0 260/CT02
	93-96		CT0 260+CT0 190/CT02+CT01
	97-100		CT0 190/CT01
	101-104		CT0 190+CTB 8000/CT01+CTB
	105-108		CTB 8000/CTB
	109-112		CTB 8000+Blue
	113-116		Blue
	117-120		Blue+White
121 - 181			Forwards rainbow effect from fast to slow
182 - 188			No rotation
189 - 249			Backwards rainbow effect from slow to fast
250 - 255			Auto random colour selection from fast to slow
			Static gobo wheel
	0-3		White

Channel	DMX	Percentage	Function		
12	4-7		Gobo1		
	8-11		Gobo2		
	12-15		Gobo3		
	16-19		Gobo4		
	20-23		Gobo5		
	24-27		Gobo6		
	28-31		Gobo7		
	32-35		Gobo8		
	36-39		Gobo9		
	40-43		Gobo10		
	44-47		Gobo11		
				<i>Shaking gobos from slow to fast</i>	
	48-60			Gobo1 Shake Slow-Fast Speed	
	61-73			Gobo2 Shake Slow-Fast Speed	
	74-86			Gobo3 Shake Slow-Fast Speed	
	87-99			Gobo4 Shake Slow-Fast Speed	
	100-112			Gobo5 Shake Slow-Fast Speed	
	113-125			Gobo6 Shake Slow-Fast Speed	
	126-138			Gobo7 Shake Slow-Fast Speed	
	139-151			Gobo8 Shake Slow-Fast Speed	
	152-164			Gobo9 Shake Slow-Fast Speed	
	165-177			Gobo10 Shake Slow-Fast Speed	
	178-190			Gobo11 Shake Slow-Fast Speed	
	191-207			Effect Shake Slow-Fast Speed	
	208-226			Forwards gobo wheel rotation from fast to slow	
	227-230			No rotation	
	231-249			Backwards gobo wheel rotation from slow to fast	
250-255			Auto random gobo selection from fast to slow		
13			Rotating gobo wheel		
			/index - set indexing on channel 14		
	0		Open/Hole (0=default)		
	1-8		Hole (flat field)		
	9-21		Gobo 1		
	22-34		Gobo 2		
	35-47		Gobo 3		
	48-60		Gobo 4		
	61-73		Gobo 5		
	74-86		Gobo 6		
	87-99		Gobo 7		
	100-112		Gobo 8		
				<i>Shaking gobo from slow to fast</i>	
				Index - set indexing on channel 14	
	113-125			Gobo 1	
	126-138			Gobo 2	
	139-151			Gobo 3	
	152-164			Gobo 4	
	165-177			Gobo 5	
	178-190			Gobo 6	
191-203			Gobo 7		
204-216			Gobo 8		
217-249			Open/hole		

Channel	DMX	Percentage	Function	
	250-255		Auto random gobo selection from fast to slow	
14			Rot. gobo indexing and rotation	
	0 - 127		Gobo indexing	
	128 - 187		Forwards gobo rotation from fast to slow	
	188-195		No rotation	
	196 - 255		Backwards gobo rotation from slow to fast	
15			Prism wheel 1	
			This wheel is blocked If Rotating gobo wheel >0 DMX	
	0-3		Open position/hole (0=default)	
			Index - set indexing on channel 16	
	4-15		Prism 3 - 6-facet linear	
	16-27		Prism 2 - 4-facet 12° circular	
	28-39		Prism 1 - 8-facet 12° circular	
			Rotation - set rotation on channel 16	
	40-51		Prism 3 - 6-facet linear	
52-63		Prism 2 - cylindrical		
64-75		Prism 1 - 8-facet 12° circular		
76-255		Raw DMX		
16			Prism wheel 1 indexing/rotation	
			Prism indexing - set position on channel 15	
	0 - 255		Prism 1 indexing	
			Prism 1 rotation - set position on channel 15	
	0-3		No rotation	
	4-34		Slow → Fast, 90° Rotating back and forth	
	35-65		Slow → Fast, 180° Rotating back and forth	
	66-96		Slow → Fast, 270° Rotating back and forth	
	97-127		Slow → Fast, 360° Rotating back and forth	
	128-188		Forwards prism rotation from fast to slow	
189-194		No rotation (128=default)		
195-255		Backwards prism rotation from slow to fast		
17			Prism wheel 2	
	0-3		Open position/hole (0=default)	
			Index - set indexing on channel 18	
	4-15		Prism - 8-facet 18° circular	
			Rotation - set rotation on channel	
	16-27		Prism - 8-facet 18° circular	
28-255		Raw DMX		
18			Prism wheel 2 indexing/rotation	
			Prism indexing - set position on channel 17	
	0-255		Prism indexing	
			Prism rotation-set position on channel 17	
	0		No rotation	
	4-34		Slow → Fast, 90° Rotating back and forth	
	35-65		Slow → Fast, 180° Rotating back and forth	
	66-96		Slow → Fast, 270° Rotating back and forth	
97-127		Slow → Fast, 360° Rotating back and forth		

Channel	DMX	Percentage	Function	
	128-188		Forwards prism rotation from fast to slow	
	189-194		No rotation (128=default)	
	195-255		Backwards prism rotation from slow to fast	
19			Pattern selection	
	0-3		Open position/hole (0=default)	
			Index - set indexing on channel 20	
	4-14		Prism macro Index 1	
	15-25		Prism macro Index 2	
	26-36		Prism macro Index 3	
	37-47		Prism macro Index 4	
	48-58		Prism macro Index 5	
	59-69		Prism macro Index 6	
	70-80		Prism macro Index 7	
			Rotation - set rotation on channel 20	
	81-91		Prism macro rotation 1	
	92-102		Prism macro rotation 2	
	103-113		Prism macro rotation 3	
	114-124		Prism macro rotation 4	
	125-135		Prism macro rotation 5	
	136-146		Prism macro rotation 6	
	147-157		Prism macro rotation 7	
	158-168		Prism macro rotation 8	
169-179		Prism macro rotation 9		
180-190		Prism macro rotation 10		
191-255		Raw DMX		
20			Pattern rotation and indexing	
			The channels are blocked: Prism Wheel 1/2, Prism Wheel 1/2 rot.	
			Pattern indexing - set position on channel 19	
	0 - 255		Pattern indexing	
			Pattern rotation - set position on channel 19	
	0		No rotation	
	1-127		Forwards pattern rotation from fast to slow	
	128		No rotation (128=default)	
	129-255		Backwards pattern rotation from slow to fast	
21			Frost	
	0-19		Open (0=default)	
	20-128		100% Light Frost	
	129-169		Pulse closing from slow to fast	
	170-210		Pulse opening from fast to slow	
	211-255		Ramping from fast to slow	
22			Zoom	
	0 - 255		Zoom from max. to min.beam angle (128=default)	
23			Zoom - fine	
	0 - 255		Fine zooming (0=default)	
24			Focus	
	0 - 255		Continuous adjustment from far to near (128=default)	
25			Focus Fine	
	0 - 255		Fine focusing (0=default)	

Channel	DMX	Percentage	Function	
26	0-255		Focus2 AutoFocus on channel 27	
			AutoFocus	
27			Autofocus (priority & distance selection)	
			Select desired distance and effect on which you need to focus and use "Focus2" channel (26) to focus the image.	
		0-15	Autofocus Off	
		16-55	10 metres	
		56-95	15 metres	
		96-135	20 metres	
		136-175	30 metres	
		176-215	40 metres	
216-255	50 metres			
28			Effect Macro	
		0-15	Reserved	
		16-25	Effect 1	
		26-35	Effect 2	
		36-45	Reserved	
		46-55	Reserved	
		56-65	Reserved	
		66-75	Reserved	
		76-85	Reserved	
		86-95	Reserved	
		96-105	Reserved	
		106-115	Reserved	
		116-125	Reserved	
		126-135	Reserved	
		136-145	Reserved	
		146-155	Reserved	
		156-165	Reserved	
		166-175	Reserved	
		176-185	Reserved	
		186-195	Reserved	
196-205	Reserved			
206-215	Reserved			
216-225	Reserved			
226-235	Reserved			
236-245	Reserved			
246-255	Reserved			



# CIRCUIT CONNECTING DIAGRAM

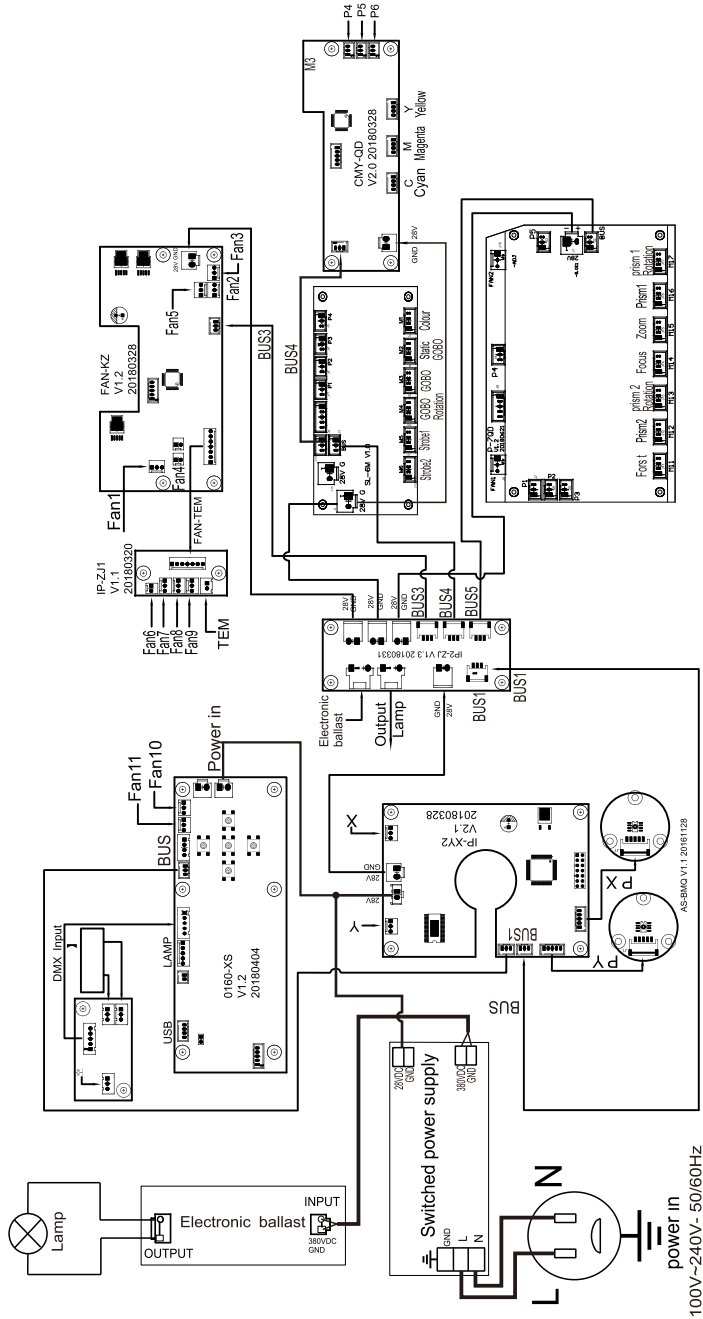

100V-240V- 50/60Hz

## CLEANING AND MAINTENANCES

- In order to ensure the projector could work normally. It should be kept clean always. It is recommended that the fans and ventilation in let should be cleaned every 15 days. The lens and dichroic colour filters should also be regularly cleaned to maintain an optimum light output. Do not use any type of solvent on dichroic colour filters. It will damage the projector.
- Suggestion: The continue usage of the light don't exceed 4 hours. Or it will shorter the usage of the lamp. Please use the alternative operation to solve this problems.
- Please disconnect the power supply when begin to maintenaceor takedown the light. Please let the parts cool down 10 minute at least then begin to install. If need to replace the lamp, please wait 10 minute again at least to let the lamp cool down completely or which maybe burned down.
- Please inspect the lens or other moving parts timing and keep them clear and static. If find anything damaged or losseness, must change a lamp or fix the lamp in order to avoid the accident.
- The light use the strong cool system. It is easy for the dirty to be collected. Please do clear the hot-sak one time two week at least.
- After you use the light, please check the intake place whether there are some wastepaper, please clean it up, or the windmill will break down and causing fire.

## TROUBESHOOTING

It is recommended some solution for some normal trouble shooting. Any unsolutedion problems should always be handle by the professional person. Disconnect the power supply before maintenance the light.

### ■ Lamp off:

- Please check if install the suitable lamp.
- Please check the connection of the power supply or switch is ok.
- Please check whether the lamp will reach the end of their life can explode, please replace a same description lamp.
- Please measure if the power supply is enough.
- Please check if the operation is correct. Please wait 30 minutes at least till the lamp cool down enough, then could the connect the power supply, which could be normal work.
- Please check whether the DMX 512 controller pass the "turn on" order.
- Please check the connection of the trigger circuit is loose contact.
- Please check whether the connected point of the trigger point is loose contact, faster the connect cable.
  - Please check if the switch of the temperature is damaged.
- Check the bottom box driver board "WK" socket if the resistance 0 between the two line.

### ■ The light beam is dark, not inhomogeneous:

- When the lamp is to the usage life, the light is not enough, please change a new one for the same description.
- Please check the reflector parts is dirty. Keep them clear.
- Please measure if the power supply is enough.
- Small adjusting is suitable for change height or screw system till get a ideal light beam.

■ **The light shadow is fogging:**

- ⊙ Please check the data on the DMX 512 controller is suitable for the electric focus.
- ⊙ Please check the mechanical parts is jamming. After cleaning, please add some temperature -durable juice.

■ **The light works interruptly:**

- ⊙ Please check if the fan works normally or mote clogging.
- ⊙ Please check whether the abstract heat have the mote clogging.
- ⊙ Please check if the lamp is to the usage life.
- ⊙ Please check if the power supply is enough, the connection of the power supply or the circuit are good.
- ⊙ Please check if the switch of the sup-temperature is good.

■ **Though the light is lighting, but it couldn't accept the control order:**

- ⊙ Please check the start code address and the function option are correct.
- ⊙ Please check whether the communicate control cable is on good connection or the cable is too long or interrupt.
- ⊙ Please check the control system is not valid, check the signal amplifier of chain connected is valid.
- ⊙ Please check whether the communicate cable is too long or the other equipment is mutually conjugate.
- ⊙ Please arrange the wire well ,, Shorter the signal cable , put the high voltage cable and low voltage cable separ -ately .
- ⊙ Add the signal amplify isolator.
- ⊙ Signal cable is used the excellent screening doublet (Resistance 75 Ω )
- ⊙ The end of the light end and the end resistance.
- ⊙ When the lamp don't cool down enough but do the incorrect operation will let the trigger up to super- high voltage leak. It will damage the electric circuit and communicate IC or CPU . Under this condition, please change the PCB board.

■ **the light can't move:**

- ⊙ Please check if the power supply is suitable for the light voltage data.
- ⊙ Please check the fuse of input voltage is defective.
- ⊙ Please check the light if they are deformatng, inside parts is broken, become wet...etc will lead the loose contact.
- ⊙ Please check if the inside lead wire and the connector is loose.
- ⊙ Please check the electric parts (such as the switch, transformer, ballast, electric capacity, piezoresistor, filter, PCB board, controller to motor) is short-circuit or burn down.

■ **Part of the projector couldn't be responsled to the controlling order:**

- ⊙ Please check the order is correct to the moving.
- ⊙ Please check the mechanical part is deformation or loose.
- ⊙ Please check the function to the motor socket is loose or drive chip is burn down.
- ⊙ Please check the wire of the motor is cut at zig point.
- ⊙ Please check these function to the motor is damaged.

■ **On working, the pan & tilt couldn't work normally:**

- ⊙ Please check according to the above step by step.
- ⊙ Please check the belt of the X.Y is broken.
- ⊙ Please check the X/Y direction data to the receiver is damage.
- ⊙ Re-projector reset.

## **DUTY EXONERATIVE AND COPYRIGHT PROTECTION**

- ◇The lamp belongs to consumption products that is not guarantee to keep it in good repair.
- ◇Any products broken that didn't according to the instruction is not guarantee to keep it in good repair.
- ◇The commentary for all the instruction belongs to the supplier in final.
- ◇No authorize can't copy.
- ◇The information in this manual may be changed in the future,the company reserve the right to change the data without any advise.